

# Appendix A

## Royalty Triggers and Reporting Rules for Royalty Assessment

## Royalty Triggers and Reporting Rules for Royalty Assessment

### 1. Introduction

The Alberta Department of Energy (the Department) has agreed with, and has adopted, the Registry reporting requirements for royalty assessment. Using the Registry data provided by facility operators, the Department assesses royalty at facilities for the owner of each product stream. Assessment is primarily based on what happens at a facility. Different royalty assessment methods are used depending on whether the previously unsold product stream is processed or unprocessed. *Refer to point 6.*

### 2. Purpose

The purpose of *Appendix A* is to outline the Department royalty triggers and illustrate certain reporting concepts that are fundamental to accurate royalty assessment.

### 3. Intended Audience

*Appendix A* is structured to provide information at the detailed level, and is designed as a *practical guide* to aid in understanding how royalty will be triggered from Volumetric/SAF/OAF and RGA data and to clarify certain reporting requirements that are necessary for accurate royalty assessment. The intended audience is the production accounting level.

### 4. The Department Terms and Definitions

A review of the following terms and definitions is beneficial to understanding the material presented in *Appendix A*. These terms and definitions are used within the context of royalty assessment by the Department and may not have universal application.

#### 4.1 Royalty Network

The royalty network is a collection of interconnected processing and gathering facilities that receive products either directly or indirectly from reservoirs. The network (for Department royalty purpose) is deemed to end when the product is delivered to:

- Commercial Transportation Facilities such as meter stations, pipelines, railcars, and trucks;
- Field Straddle Plants (except in the case of unprocessed product where the network is deemed to end at the field straddle plant outlet gate, whether or not any processing of the product occurs);
- Mainline Straddle Plants;
- Fractionation Plants;
- Injection Facilities;
- Facilities outside the Province of Alberta (except non-Alberta facilities on the Department approval list); *and*
- Refineries, Terminals, Treating Plants.

## 4.2 Processing

Processing is the action of creating new product(s) from existing product(s) by:

- Extracting component gases and/or liquids from a product;
- Combining two or more products; *and*
- Altering the state in which a product exists (i.e., changing a product from a gaseous state to a liquid state).

Processing excludes the separation and/or recombination of product(s) produced at a well that is necessary for the purpose of an initial measurement and transportation.

## 4.3 Unsold Stream

A movement of product originating at a reservoir and moving through a network to the point where ownership of the product changes hands.

## 4.4 Unprocessed Stream

A movement of effluent recovered from a formation in any form (gas, liquid or solid). Effluent becomes an unprocessed stream for reporting after the first point of measurement.

## 4.5 Processed Stream

A processed stream originates at the first point where the product stream is processed after the initial wellhead separation/measurement point.

## 4.6 Purchased Stream

A movement of product originating at the point where ownership changed from one business associate (legal entity) to another. A stream can be purchased and sold several times within the network.

## 4.7 Volumetric Activity "Production"

An unsold, unprocessed product stream, composed of products recovered from a formation in gaseous or liquid form, which originates at the first point of measurement after the wellhead, and ends at the first processing point.

## 4.8 Product "Gas"

An unsold and processed product stream composed mainly of methane, which is left over after natural gas is processed (residue gas). Natural gas is processed in order to remove heavier components (natural gas liquids), hydrogen sulphide and/or other impurities from the gas. The residue is the portion of the original gas, which remains after processing.

## 4.9 IN-NET Facility (within royalty network)

A facility location on the Volumetric/SAF/OAF that is within the royalty network. Province Code = AB, Type Code = BT/GS/GP. The GP referenced here is a conventional gas processing plant.

**4.10 OUT-NET Facility** (outside of royalty network)

A facility location on the Volumetric/SAF/OAF that is outside the royalty network  
 Province Code = AB, Type Code = MS/IF/RF/TM/PL/RR/TR/EG/ or a gas plant -  
 (GP) which is a mainline or fractionation plant, or a non-Alberta facility location.

**Department (DOE) – Volumetric Royalty Trigger Summary Table**

<b>Royalty Trigger Type</b>	<b>Registry Volumetric Reporting Facility</b>	<b>Registry Volumetric Activity</b>	<b>Registry Volumetric From/To Location</b>	<b>Product</b>	<b>SAF and OAF required?</b>	<b>Royalty Trigger Location</b>	<b>Royalty Trigger Action</b>
Dispositions out of royalty network	IN-NET	DISP	OUT-NET	Gas	Yes	Reporting Facility	Crown Royalty charge
Dispositions out of royalty network with return fuel	IN-NET (facility is the associated return fuel/gas lift facility of the BT or GS that is receiving gas from an MS)	DISP	OUT-NET	Gas	Yes	Reporting Facility	Crown Royalty charge
	AB-BT or GS with an associated return fuel/gas lift facility	REC	AB-MS	Gas	Yes	Associated Return Fuel/Gas Lift Facility	Crown Royalty reduction at associated return fuel/gas lift facility.  If no associated return fuel facility is indicated, reduction will be at the associated gas lift facility.  No reduction given if there is no crown royalty charge at the associated facility.  No reduction given if there is no FUEL activity at the reporting facility.

**Appendix A –Royalty Triggers and Reporting Rules for Royalty Assessment**

Royalty Trigger Type	Registry Volumetric Reporting Facility	Registry Volumetric Activity	Registry Volumetric From/To Location	Product	SAF and OAF required?	Royalty Trigger Location	Royalty Trigger Action
	AB-BT or GS with an associated return fuel/gas lift facility	FUEL	N/A	Gas	Optional	Associated Return Fuel/Gas Lift Facility	Validates the return fuel reduction at the associated return fuel/gas lift facility.
By-Products Processing	AB-GS or GP	PROC	N/A	Any except Gas	Yes	Reporting Facility	Crown Royalty Charge
Royalty Liabile Lease Fuel	AB-BT, GS or GP	PURDISP	AB-BT or GS	Gas	Yes	Reporting Facility	Crown Royalty charge
Injection Credit	AB-IF	REC	Any	Any	Yes	Reporting Facility	Injection Credit  No injection credit is given if there is no INJ activity at the reporting facility.
	AB-IF	DISP	Any	Any	Optional	Reporting Facility	Injection Credit reduction.  <i>Injection credit is net of deliveries from the injection facility.</i>
	AB-IF	INJ	N/A	Any	Optional	Reporting Facility	Validates the injection credit at the injection facility.

**AB** Alberta  
**BT** Battery

**GP** Gas Plant  
**GS** Gas Gathering System  
**IF** Injection Facility

**IN-NET** AB-BT, GS, GP, and Field Straddle Plants processing *native* gas,

**OUT-NET** AB-Injection facilities, AB-Meter Stations/Pipelines, AB-Mainline Straddle Plants, AB-Field Straddle Plants processing *non-native* gas, AB-Commercial, Residential, Electrical Generation facilities, and Non AB facilities

**PROC** Process  
**PURDISP** Purchased Disposition  
**REC** Receipt  
**DISP** Disposition  
**INJ** Injection

**Royalty Trigger Sub Types**

The royalty trigger types are further divided where there are in-network gas sales involved as different crown royalty rules apply. In-network gas sales are reported on Raw Gas Allocation (RGA) submissions. See *RGA Reporting* for further information on RGA submissions. For clients who are receiving their Crown Royalty Details in User Defined Files (UDF) format, the royalty trigger descriptions in the UDF are indicated by royalty trigger sub types.

**Appendix A –Royalty Triggers and Reporting Rules for Royalty Assessment**

Royalty Trigger Type	Royalty Trigger Sub Type	Trigger Code
Dispositions to Out of Network	Disposition Out-of-Network	DISP
	Raw Gas Disposition (no processing)	RGAD
	Raw Gas Disposition with Processing only	RGADP
	Raw Gas Delivered to Injection	RGAIF
By-Products Processing	By-Product Processing	PROC
	Raw Gas Processing	RGAP
Royalty Liable Lease Fuel	Royalty Liable Lease Fuel	PURDSP
	Raw Gas Lease Fuel	RGAPUR
Injection Credit	Injection Credit	INJECT
	Injection Disposition	INJDSP
Disposition to Out of Network with Return Fuel	Disposition with Return Fuel	DISPRF
	Raw Gas Disposition with Return Fuel (no Processing)	RGADR
	Raw Gas Disposition with Processing & Return Fuel	RGDPR

**5. Legends Used in This Section:**

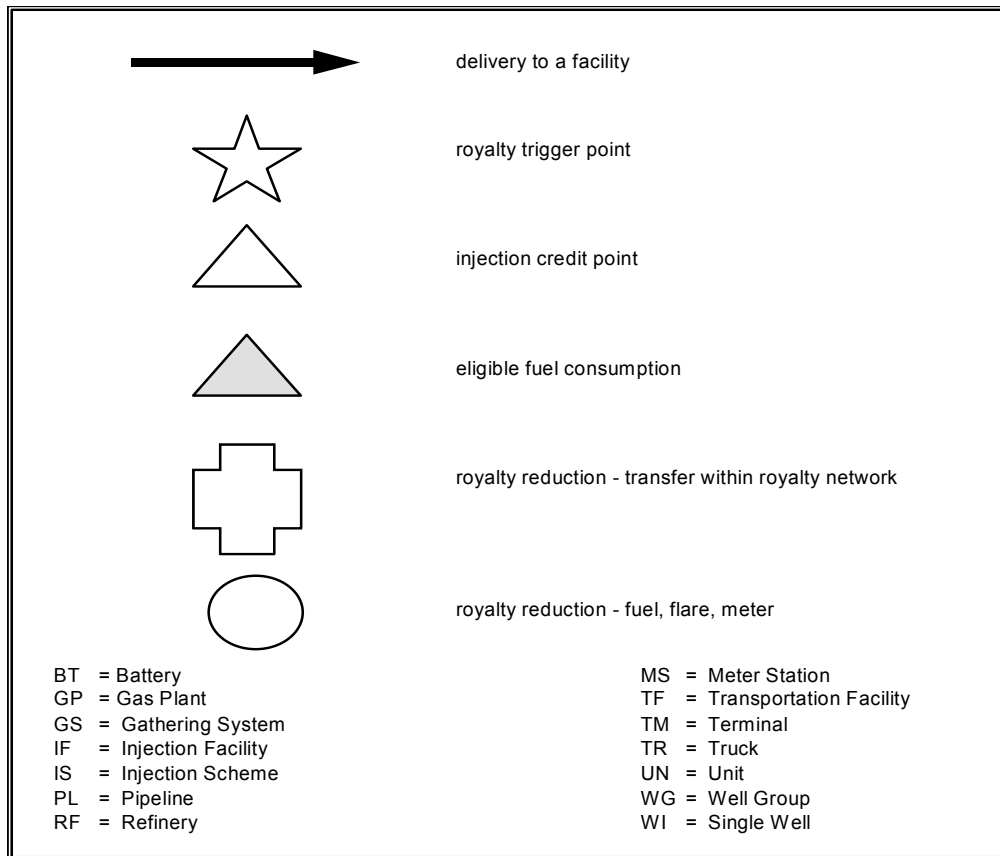

## 6. Royalty Triggers, Injection Credits, Other Royalty Reductions and Supporting Royalty Assessment Method Details

Royalty Triggers are based on what happens at the facility. The method of assessment depends on whether the product stream is processed or unprocessed, and on what activity is happening at the facility where the royalty assessment takes place. The royalty assessment methods chosen are the result of joint endeavours between the Department and the petroleum and gas industry. The following items identify the locations where the Department royalty assessments are triggered when the described business events occur.

### 6.1 Royalty Assessment Methods for In-Net Facility Disposition to Out of Net Facility

Facility (excluding Straddle Plants) where previously unsold gas is:

- Delivered to Mainline Straddle Plants, Commercial Transportation Facilities, destinations such as meter stations, refineries, terminals, treating plants, or non-Alberta facility locations; *or*
- Delivered to Injection Facilities.

For previously unsold, *unprocessed* gas at a facility (excluding straddle and fractionation plants) where stream is *not processed*, stream royalty assessable volume equals:

Volume dispositions (transferred) to out of network facilities.
---

Refer to *Appendix A* page 7 for Volumetric/ SAF/ OAF reporting detail.

The required facility reporting will change if the volumes are Cascaded, there is Return Fuel, or a Raw Gas sale occurs upstream. Examples of Volumetric/ SAF/ OAF and RGA reporting are provided from page 9 to page 11 for these situations.



**Royalty Trigger Type (DISP) - Disposition to Out of Network with 2 Level Cascade**

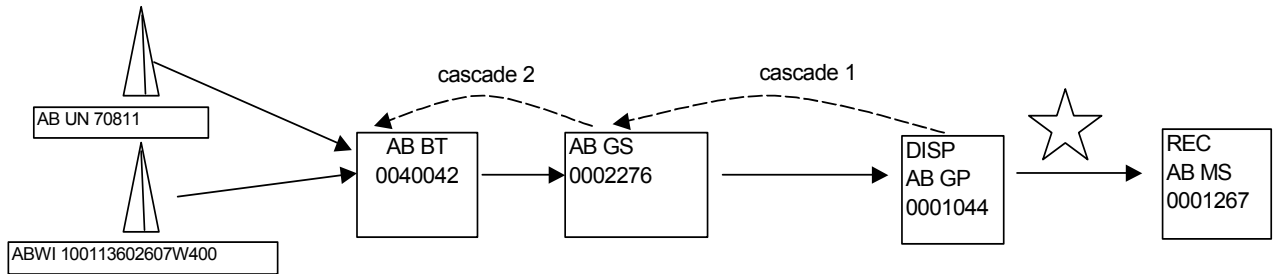

	Reporting Facility	Activity	Product	To/From Facility	Vol	ISC Breakdown	ISC Vol	Heat		Client Volumetric	
Volumetric	AB GP 0001044	DISP	GAS	AB MS 0001267	10475	C1-IC	4713.8	193263.75		Charge Facility	Vol
						C2-IC	5761.3	236211.25			
						Total	10475	429475			
						Stream Id		SAF Factor	Cascade Fac		
SAF	AB GP 0001044	DISP	GAS	AB MS 0001267		AB GS 0002276		1			
SAF	AB GS 0002276	DISP	GAS	AB MS 0001267		AB BT 0040042		1	AB GP 0001044		
SAF	AB BT 0040042	DISP	GAS	AB MS 0001267		AB UN 70811		0.55	AB GS 0002276		
						AB WI 100113602607W400		0.45			
						Owner	OAF Factor				
OAF	AB BT 0040042	DISP	GAS	AB MS 0001267		AB UN 70811	XXX1	0.3	AB GS 0002276	AB GP 0001044	1728.4
							XXX2	0.7	AB GS 0002276	AB GP 0001044	4032.9
OAF	AB BT 0040042	DISP	GAS	AB MS 0001267		AB WI 100113602607W400	XXX3	1	AB GS 0002276	AB GP 0001044	4713.8
											10475.0

Notes:



: Indicates Royalty Trigger Point

- An OAF is only required at the final facility in the cascade chain, should there be more than one cascade. The OAF cascade facility will match the final SAF cascade facility.
- The royalty charge is at the facility where the volumetric trigger information is filed.
- SAF Reporting is required at each facility in response to a cascade.

**Royalty Trigger Type - Disposition to Out of Network with Return Fuel**

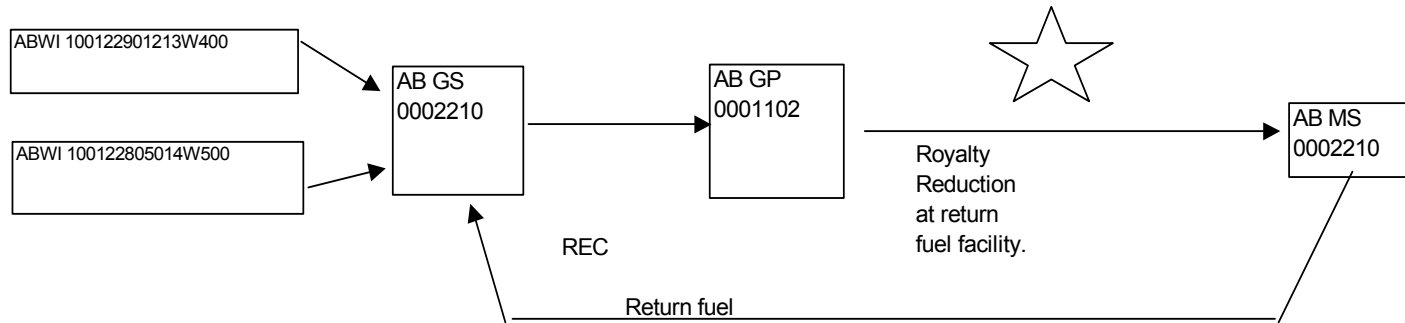

	Reporting Facility	Activity	Product	To/From Facility	Vol	ISC Breakdown	ISC Vol	Heat	Royalty Reduction Vol	Royalty Reduction Heat	Point of Determination Facility
Volumetric	AB GS 0002210	REC	GAS	AB MS 0002210	30		30	1230			
	AB GS 0002210	FUEL	GAS	AB MS 0002210	35		35	1435			
SAF	AB GS 0002210	REC	GAS	AB MS 0002210		AB WI 100122901213W400 AB WI 100122805014W500		0.55 0.45			
							Owner	OAF Factor			
OAF	AB GS 0002210	REC	GAS	AB MS 0002210		AB WI 100122901213W400	XXX1	0.3	4.95	202.95	AB GP 1102
							XXX2	0.7	11.55	473.55	AB GP 1102
OAF	AB GS 0002210	REC	GAS	AB MS 0002210		AB WI 100122805014W500	XXX7	0.2	2.7	110.7	AB GP 1102
							XXX6	0.8	10.8	442.8	AB GP 1102
									30	1230	

Note: Reporting details for return fuel continued on following page.

This diagram shows the Crown royalty situation associated with the Return Fuel example above

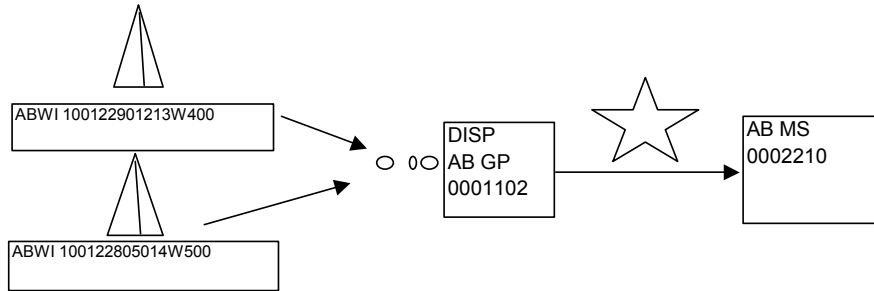

										Client Volumetric			
										Volume 103M3			
	Reporting Facility	Activity	Product	To/From Facility	Vol	ISC Breakdown	ISC Vol	Heat	Charge Fac	Gross Vol	Less Return Fuel Vol	Net royalty Liabile Vol	
Volumetric	AB GP 1102	DISP	GAS	AB MS 1004	900	C1-IC	585	23985					
						C4-IC	315	12915					
						Total	900	36900					
						Stream Id		SAF Factor					
SAF	AB GP 1102	DISP	GAS	AB MS 1004		AB WI 100122901213W400		0.55					
						AB WI 100122805014W500		0.45					
						Owner		OAF Factor					
OAF	AB GP 1102	DISP	GAS	AB MS 1004		AB WI 100122901213W400	XXX1	0.3	AB GP 1102	148.5	4.95	143.55	
							XXX2	0.7	AB GP 1102	346.5	11.55	334.95	
OAF	AB GP 1102	DISP	GAS	AB MS 1004		AB WI 100122805014W500	XXX7	0.2	AB GP 1102	81	2.7	78.3	
							XXX6	0.8	AB GP 1102	324	10.8	313.2	
										900	30	870	

Notes:



: Indicates Royalty Trigger Point

- Return Fuel royalty reduction only applies to product GAS
- Return Fuel royalty reduction only applies to BT or GS, not GP
- Require both REC from a meter station and FUEL activity
- The Return Fuel facility must be tied to the facility that has Crown royalty charges

Trigger Type:

- DISPRF Trigger Type Disposition with Return Fuel
- RGADR Trigger Type Raw Gas Disposition with Return Fuel (no processing)
- RGDPR Trigger Type Disposition with Return Fuel

**Royalty Trigger Type - Raw Gas Sale Subsequently processed**

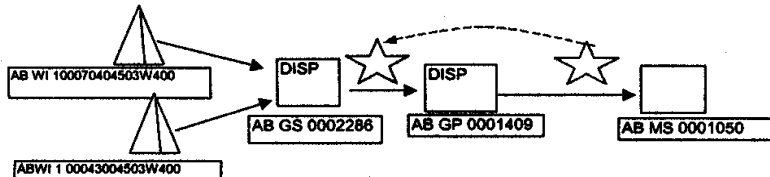

	Reporting Facility	Activity	Product	To/From Facility	Vol	ISC Breakdown	ISC Vol	Heat	Cascade Fac										
Volumetric	AB GP 0001409	DISP	GAS	AB MS 0001050	1000	C1-IC	330	13530											
						C5-IC	330	13530											
						C2-IC	340	13940											
						Total	1000	41000											
	AB GP 0001409	PROC	C3-SP	Blank	100														
	AB GP 0001409	PROC	C5-SP	Blank	150														
	AB GP 0001409	PROC	C4-SP	Blank	200														
						Stream Id		SAF Factor											
SAF	AB GP 0001409	DISP	GAS	AB MS 0001050		AB GS 0002286		1											
	AB GP 0001409	PROC	ALL	Blank		AB GS 0002286		1											
SAF	AB GS 0002286	DISP	GAS	AB MS 0001050		AB WI 100070404503W400		0.55	AB GP 0001409	<b>Example - Volumetric Calculation for Well 10070404503W400</b>									
						AB WI 100043004503W400		0.45	AB GP 0001409	Client XXX1									
										Charge Fac	Product	Vol Alloc	Gas Equiv	Total 103M3	GJ Alloc	GJ Conv Factors			
SAF	AB GS 0002286	PROC	ALL	Blank		AB WI 100070404503W400		0.55	AB GP 0001409	AB GS 0002286	GAS	165	1	165	6765				
						AB WI 100043004503W400		0.45	AB GP 0001409		C3-SP	16.5	0.27201	4.488165	421.60027	93.936			
											C4-SP	33	0.23331	7.69923	934.73272	121.406			
											C5-SP	24.75	0.2057	5.091075	760.41824	149.363			
														182.3	8882				
OAF	AB GS 0002286	DISP	GAS	AB MS 0001050		AB WI 100070404503W400	XXX1	0.3	AB GP 0001409	Owner	OAF Factor								
						AB WI 100043004503W400	XXX2	0.7	AB GP 0001409										
						AB WI 100070404503W400	XXX2	1	AB GP 0001409										
OAF	AB GS 0002286	PROC	ALL	Blank		AB WI 100070404503W400	XXX1	0.3	AB GP 0001409										
						AB WI 100043004503W400	XXX2	0.7	AB GP 0001409										
						AB WI 100070404503W400	XXX2	1	AB GP 0001409										
RGA	AB GS 0002286		GAS	AB MS 0001050		AB WI 100070404503W400	XXX1	1	165	AB GS 0002286									
RGA	AB GS 0002286		GAS	AB MS 0001050		AB WI 100070404503W400	XXX2	1	385	AB GS 0002286									
RGA	AB GS 0002286		GAS	AB MS 0001050		AB WI 100043004503W400	XXX2	1	450	AB GS 0002286									

Notes:



: Indicates Royalty Trigger Point

Trigger Types:

- RGADP RGA with DISP and Proc activities
- RGAD RGA with only DISP activity
- RGAP RGA with only PROC activity

When in-net sale take place, a Raw Gas Allocation Factor (RGA) is filed by the operator of the selling facility.

A raw gas sale can apply to both liquid products and gas. Whenever liquids are part of a raw gas sale, they are converted to gas equivalent energy units – gigajoules – for the calculation of royalty.

**Royalty Assessment Method for Facility Gas Disposition to Field Straddle Plant**

Occurring where previously unsold, processed gas is delivered to a Field Straddle Plant. Royalty assessment is based on whether the gas stream is processed or unprocessed upon receipt at facility, and on what is happening to the stream at the facility prior to delivery to the Field Straddle Plant. By-product streams resulting from processed by-products are not subject to royalty assessment because royalties would have been charged when the by-products were extracted from the gas stream.

**Royalty Trigger Type (DISP) - Straddle Plant Processing Native Gas**

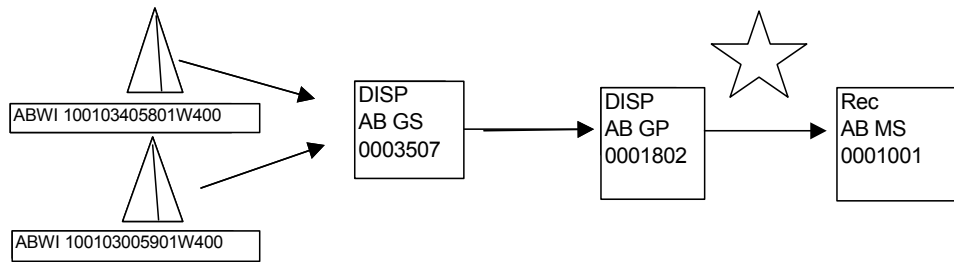

	Reporting Facility	Activity	Product	To/From Facility	Vol	ISC Breakdown	ISC Vol	Heat	Client Volumetric				
Volumetric	AB GP 0001802	DISP	GAS	AB MS 0001001	12345	C1-IC	9876	404916		Charge Fac	Vol	GJ	
						C2-IC	1234.5	50614.5					
						C3-IC	617.25	25307.25					
						C5-IC	617.25	25307.25					
						Total	12345	506145					
						Stream Id		SAF Factor	Cascade				
SAF	AB GP 0001802	DISP	GAS	AB MS 0001001		AB GS 0003507		1					
SAF	AB GS 0003507	DISP	GAS	AB MS 0001001		AB WI 100103405801W400		0.55	AB GP 0001802				
						AB WI 100103005901W400		0.45	AB GP 0001802				
							Owner	OAF Factor					
OAF	AB GS 0003507	DISP	GAS	AB MS 0001001		AB WI 100103405801W400	XXX1	0.3	AB GP 0001802	AB GP 0001802	2036.9	83514	
							XXX2	0.7	AB GP 0001802	AB GP 0001802	4752.8	194866	
OAF	AB GS 0003507	DISP	GAS	AB MS 0001001		AB WI 100103005901W400	XXX3	1	AB GP 0001802	AB GP 0001802	5555.3	227765	
											12345	506145	

Note: : Indicates Royalty Trigger Point

For a unique straddle plant approved for processing native gas, the royalty is triggered at the plant gate of the field straddle plant determined from the stream level reporting in the SAF detail.

### Royalty Assessment Method for Processed Gas

For products *other than Gas* at a facility (excluding straddle and fractionation plants) where they are extracted from a previously unsold *gas* stream, stream royalty assessable volume equals:

**Royalty Trigger (PROC) - By-product processing**

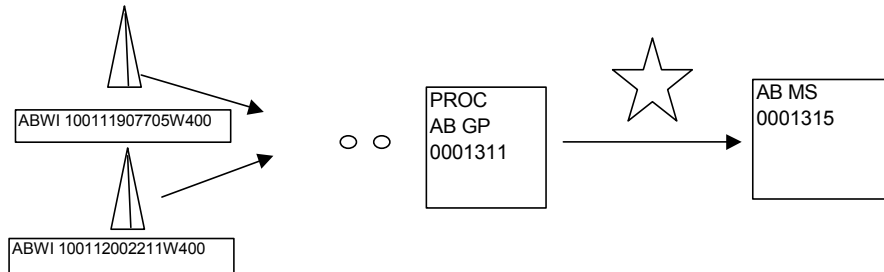

Volumetric	Reporting Facility	Activity	Product	To/From Facility	Vol	Vol	Client Volumetric							
							C2-SP	C2-MX	C3-SP	C3-MX	C4-SP	C4-MX		
	AB GP 0001311	PROC	C2-SP	blank		100								
			C2-MX	blank		0								
			C3-SP	blank		0								
			C3-MX	blank		45								
			C4-SP	blank		50								
			C4-MX	blank		25								
			C5-SP	blank		400								
			C5-MX	blank		350								
			SBASE	blank		100								
			SBLOC	blank		150								
			SMOLT	blank		250	500							
							Stream Id	SAF Factor	C2-SP	C2-MX	C3-SP	C3-MX	C4-SP	C4-MX
SAF	AB GP 0001311	PROC	C2-SP	blank			AB WI 100111907705W400	0.55	55	0	0	24.75	27.5	13.75
			C2-SP	blank			AB WI 100112002211W400	0.45	45	0	0	20.25	22.5	11.25
			C2-MX	blank					100	0	0	45	50	25
			C3-SP	blank										
			C3-MX	blank										
			C4-SP	blank										
			C4-MX	blank										
			C5-SP	blank										
			C5-MX	blank										
			SBASE	blank										
			SBLOC	blank										
			SMOLT	blank										

OAF Reporting for By-Product processing( Continued from A-13)

						Owner	OAF Factor	C2-SP	C2-MX	C3-SP	C3-MX	C4-SP	C4-MX	
OAF	AB GP 0001311	PROC	C2-SP	blank	████████	AB WI 100111907705W400	XXX1	0.3	16.5	0	0	7.425	8.25	4.125
							XXX2	0.7	38.5	0	0	17.325	19.25	9.625
			C2-MX	blank					55	0	0	24.75	27.5	13.75
			C3-SP	blank										
			C3-MX	blank										
			C4-SP	blank										
			C4-MX	blank										
			C5-SP	blank										
			C5-MX	blank										
			SBASE	blank										
			SBLOC	blank										
			SMOLT	blank										
OAF	AB GP 0001311	PROC	C2-SP	blank	████████	AB WI 100112002211W400	XXX3	1	45	0	0	20.25	22.5	11.25
			C2-MX	blank										
			C3-SP	blank										
			C3-MX	blank										
			C4-SP	blank										
			C4-MX	blank										
			C5-SP	blank										
			C5-MX	blank										
			SBLOC	blank										
			SMOLT	blank										
			SBASE	blank										

Notes:

**Royalty Assessment Method for Injection Credits**

Facility where product received will be:

- Injected into a production-motivated scheme (including cycling schemes); *and*
- Consumed during the process of injecting product(s) into a production motivated injection scheme; *but*
- Excludes approved storage schemes.

Injection credit volume equals Receipts *minus* Dispositions:

Royalty Trigger Type - Injection Credit

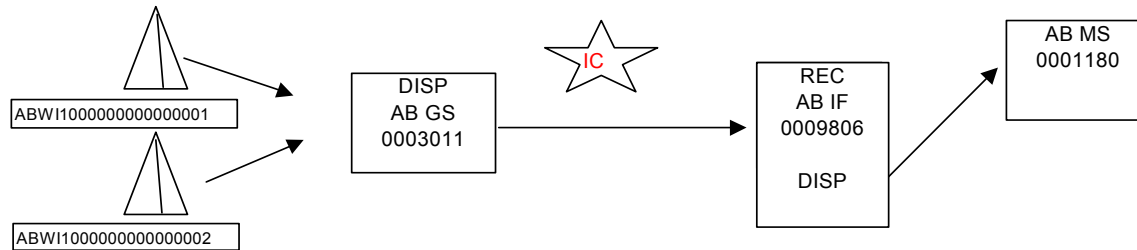

										Client Volumetric		
Volumetric	AB IF 0009806	REC	GAS	AB GS 0003011	555	C1-IC	349.65	14335.65		Charge Fac	Vol	GJ
						C5-IC	205.35	8419.35				
						Total	555	22755				
	AB IF 0009806	DISP	GAS	AB MS 0001180	73	C1-IC	45.99	1885.59				
						C5-IC	27.01	1107.41				
						Total	73	2993				
	Injection credit is calculated on net receipts volume				482			19762				
	AB IF 0009806	INJ	GAS		27	C1-IC	17.01	697.41				
						C5-IC	9.99	409.59				
						Total	27	1107				
						Stream Id		SAF Factor				
SAF	AB IF 0009806	REC	GAS	AB GS 0003011		AB IS 10044		0.55				
						AB IS 10071		0.45				
						Owner	OAF Factor					
OAF	AB IF 0009806	REC	GAS	AB GS 0003011		AB IS 10044	XXX1	0.3	AB IF 0009806	79.53	3260.73	
							XXX2	0.7	AB IF 0009806	185.57	7608.37	
OAF	AB IF 0009806	REC	GAS	AB GS 0003011		AB IS 10071	XXX3	1	AB IF 0009806	216.9	8892.9	
										482	19762	

Notes



: Indicates Royalty Trigger Point

\*Injection Credit is calculated by taking the receipts less disposition (I.e. 555-73=482)

Trigger Type:

INJECT - injection with no DISP activity

INJDSP - injection with DISP activity (as in above example)

**NOTE:** VOLUMES RECEIVED FOR INJECTION PURPOSES ARE VOLUMES RECEIVED AT THE INJECTION FACILITY, WHICH ARE EITHER INJECTED OR CONSUMED DURING THE PROCESS OF INJECTING GAS AND GAS PRODUCTS INTO A PRODUCTION-MOTIVATED INJECTION SCHEME. THIS EXCLUDES ANY SUBSEQUENT DELIVERY OF VOLUMES FROM THE INJECTION FACILITY. INJECTION LINE IS REQUIRED REPORTING.

**Royalty Assessment Method for Royalty Liable Lease Fuel:**

If the product stream is not reprocessed at the facility where it is returned for fuel consumption, a royalty liability will be assessed.

**Royalty Trigger Type - Royalty Liable Lease Fuel**

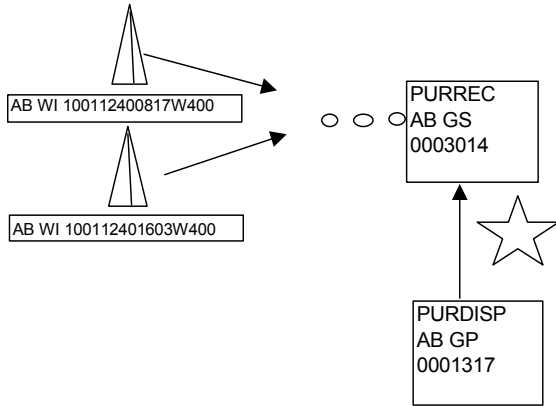

											Client Volumetric		
	Reporting Facility	Activity	Product	To/From Facility	Vol	GJ	ISC Breakdown	ISC Vol	Heat		Charge Facility	Vol	GJ
Volumetric	AB GP 0001317	PURDISP	GAS	AB GS 0003014	330	13530							
							Stream Id		SAF Factor				
SAF	AB GP 0001317	PURDISP	GAS	AB GS 0003014			AB WI 100112400817W400		0.55				
							AB WI 100112401603W400*		0.45				
								Owner	OAF Factor				
OAF	AB GP 0001317	PURDISP	GAS	AB GS 0003014			AB WI 100112400817W400	XXX1	0.3		AB GP 0001317	54.45	2232.45
								XXX2	0.7		AB GP 0001317	127.05	5209.05
OAF	AB GP 0001317	PURDISP	GAS	AB GS 0003014			AB WI 100112401603W400	XXX2	1		AB GP 0001317	148.5	6088.5
												330	13530

Notes



: Indicates Royalty Trigger Point

Royalty Liable lease fuel is gas that is sold to a BT or GS, from another BT, GS or GP, for use as lease fuel. PURDISP activity only applies to Product gas.

Trigger Type:

PURDISP : Trigger Type indicates Purchased disposition for lease fuel

RGAPUR : Trigger Type indicates Raw gas purchased for lease fuel

Enhance Oil Recovery (EOR) - Unit Operating Cost Recapture

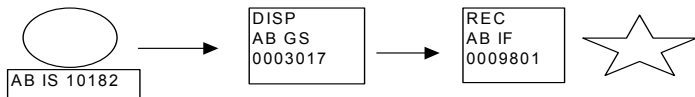

	Reporting Facility	Activity	Product	To/From Facility	Vol	ISC Breakdown	ISC Vol	Heat		Point of Determination Facility	Charge Type	Client Volumetric	
												Vol	GJ
Volumetric	AB IF 0009801	REC	GAS	AB GS 0003077	100	C1-IC		55	2255				
	AB IF 0009801	INJ	GAS			C2-IC		45	1845				
						Total		100	4100				
						Stream Id			SAF Factor				
SAF	AB IF 0009801	REC	GAS	AB GS 0003077		AB IS 10182			1.00				
							Owner		OAF Factor				
OAF	AB IF 0009801	REC	GAS	AB GS 0003077		AB IS 10182	XXX1	0.3		AB IF 0009801	IC	30	1230
							XXX2	0.7		AB IF 0009801	IC	70	2870
												100	4100

\*Injection line required

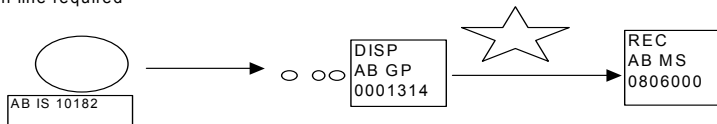

	Reporting Facility	Activity	Product	To/From Facility	Vol	ISC Breakdown	ISC Vol	Heat		Point of Determination	Charge Type	Client Volumes	
Volumetric	AB GP 0001314	DISP	GAS	AB MS 0806000	120	C1-IC		66	2706				
						C2-IC		38.4	1574.4				
						C4-IC		15.6	639.6				
						Total		120	4920				
						Stream Id			SAF Factor				
SAF	AB GP 0001314	DISP	GAS	AB MS 0806000		AB IS 10182			1.00				
							Owner		OAF Factor				
OAF	AB GP 0001314	DISP	GAS	AB MS 0806000		AB IS 10182	XXX1	0.3		AB GP 0001314	CR	36	1476
							XXX2	0.7		AB GP 0001314	CR	84	3444
												120	4920

Stream Id	Owner	Royalty Liabile Quantity	Point of Determination	Charge Type	UOCR Recapture Volumetric	
AB IS 10182	XXX1	0	AB IF 0009801	EOR	30	1230
	XXX2	0	AB IF 0009801	EOR	70	2870
					100	4100

Notes:



: Indicates Royalty Trigger Point

Where gas and gas products are injected into an EOR scheme, approved under the **Enhanced Recovery\*** of Oil Royalty Reduction Regulation, the Crown will recover operating costs previously deducted from Crown royalty. The Crown share of the operating costs to be recovered will be calculated on the lesser of the royalty client's proprietary volumes produced versus those injected into the same EOR scheme in the same month.

