

Appendix G

Allowable and Non- Allowable Capital Costs

Overview

The Minister may approve additions/deletions to the list of allowable costs or require additions to the list of non-allowable costs. Where such an addition/deletion occurs, the Department:

- Will announce the addition directly to the applicant and in an *Information Letter*; and
- Will include that addition in the next update of the *Guidelines*.

Allowable Capital Costs

Eligible capital costs incurred in Alberta include those costs pertaining to assets that can be directly attributed to the gathering, compression or processing of natural gas and related gas by-products. Costs incurred outside the royalty network are not considered eligible.

The total capital cost includes charges that can be directly attributed to the particular project including, but not limited to: engineering, design, construction, testing and implementation. Eligible capital costs are generally incurred on-site; however, other costs such as in-house engineering may be allowed if the charges are directly related to the specific capital project being claimed.

Capital charges only become eligible for inclusion as an allowable cost on or after the first day that the capital commences commercial production of gas and/or related gas by-products.

Where the use of capital assets is shared between eligible and ineligible activities, Facility Cost Centre (FCC) operators are permitted to include a portion of the total costs as an allowable capital expenditure. A reasonable allocation methodology should be used to establish the portion to be included for Allowable Cost purposes. The Department will review the allocation methodology and has final approval. Allocation between eligible and ineligible activities may be based on the reasonable pro-ration of inputs/outputs including, but not limited to: production volumes, kilowatt hours, horsepower, labour time spent, distance, fuel consumed, property or other tax assessments.

Leases

Where an eligible asset is leased, the costs associated with the lease may be considered either an operating expense or a capital expense in nature. The Department will make this determination of the type of lease using Generally Accepted Accounting Principles (GAAP). Under these principles, a lease would normally be considered a capital expense if substantially all of the benefits and risks associated with the property is transferred to the lessee.

Financing charges pertaining to the lease are not eligible as an Allowable Capital Cost.

The following are examples of *allowable capital costs incurred in Alberta* identified by the Minister, as referenced in *Ch III, Sec. 3.4*. The attached facility schematic represents an approximate illustration of the capital assets, which are generally considered eligible for Allowable Costs. If a particular asset or activity is not identified in the diagram or in the list below clarification as to eligibility can be obtained by contacting the Gas Royalty Client Services.

- Air strips located on site. Aircraft are not included.
- Capital leases (see leases).
- Automatic equipment for gathering, compressing and processing facilities.
- Communication controls for eligible capital assets.
- Field or inlet compression facilities required to meet gathering system or plant inlet pressure specifications.
- Construction overhead as specified in joint venture agreements (normally 5-3-1), or in the absence of a joint venture agreement or where an FCC is owned 100%, overhead on construction is allowed at a maximum rate of 1% of direct capital costs.
- Corrosion protection.
- Electrical generation equipment where the output is used to operate eligible capital assets. Please refer to Information Letter 2001-34 Energy Efficiency Credit Program (EECP) for restrictions.
- Cost of easements or rights-of-way.
- Effluent basins and facilities for handling and disposal of fresh water used in processing.
- Maintenance of emergency flare stacks and relief facilities including wellsite flare stacks.
- Fire fighting and safety equipment.
- Fuel lines for gathering, compression and processing facilities.
- Gas recovery related costs occurring after the point of **final** separation of solution gas from oil.
- Installed costs of gathering lines to the plant or field compressor from gas wells, or from the point of **final** separation for solution gas from oil.
- Actual or imputed interest or other financing costs, not exceeding the prime rate of interest posted monthly by the Department of Energy, will be allowed as part of the cost of new facility and capital additions to an existing facility up to the production start-up date. Interest on construction is calculated monthly during the construction period using the current months approved interest rate multiplied by the accumulated capital cost amount incurred from the previous month. Interest is not compounded.
- Line heaters at well heads and on gathering systems.
- Meter runs and measurement equipment including buildings.
- On-site training facilities.
- Pollution monitoring and seepage detection equipment.
- Process license fees.
- Processing facilities.
- Processing and engineering studies that relate directly to the process used or eligible asset acquired.
- Roads, bridges, walkways and fences for compressing and processing facilities only.
- Separators, dehydrators, scrubbers, and any other eligible assets related to non-associated gas.

- Storage tanks for field separated liquids (other than oil and water), chemicals or other substances required for gathering, compression and processing activities.
- Sulphur-forming facilities (prilling, slaters and remelters).
- Vehicles and mobile equipment.
- Warehouses, laboratories and plant offices.
- Water treatment facilities if water is used for processing.

Non-Allowable Capital Costs

The following are the *non-allowable capital costs* approved by the Minister, as referenced in *Ch III, Section 3.4*:

- Capital assets dedicated to the production function including drilling equipment or other down-hole equipment.
- Capital costs incurred prior to the point of final separation of solution gas from oil.
- Assets used for handling field condensate downstream of the point where condensate royalty has already been paid.
- Crude oil equipment including transportation and storage facilities, separators, vehicles, dehydrators, scrubbers, boots, and any other facilities or equipment relating to oil.
- Assets located outside of the royalty network.
- Assets located outside of Alberta.
- Capital costs that are deemed, indirect or estimated.
- Gas or by-product loading facilities, railway spur lines, storage vessels, or other facilities beyond the plant gate or downstream of the royalty trigger point.
- Housing unless located directly at the plant site.
- Other capital assets that are not directly attributable to gathering, compressing and processing functions as they relate to natural gas and gas related by-products.
- Lines, compressors, wells and other significant facilities or equipment relating to the injection function.
- Off-site depots for vehicles and equipment servicing more than one facility.
- Off-site training facilities.
- Down hole, wellhead, protection, controlling, servicing, testing, salt water, and other production facilities or equipment relating to the production function.
- Capital assets approved under the Sulphur Emission Control Assistance Program (SECAP), CO₂ Projects Royalty Credit Program or Gas Processing Efficiency Assistance Program (GPEAR) must be removed from the Allowable Cost claim.
- Roads, bridges, walkways and fences for wellhead and gathering facilities.

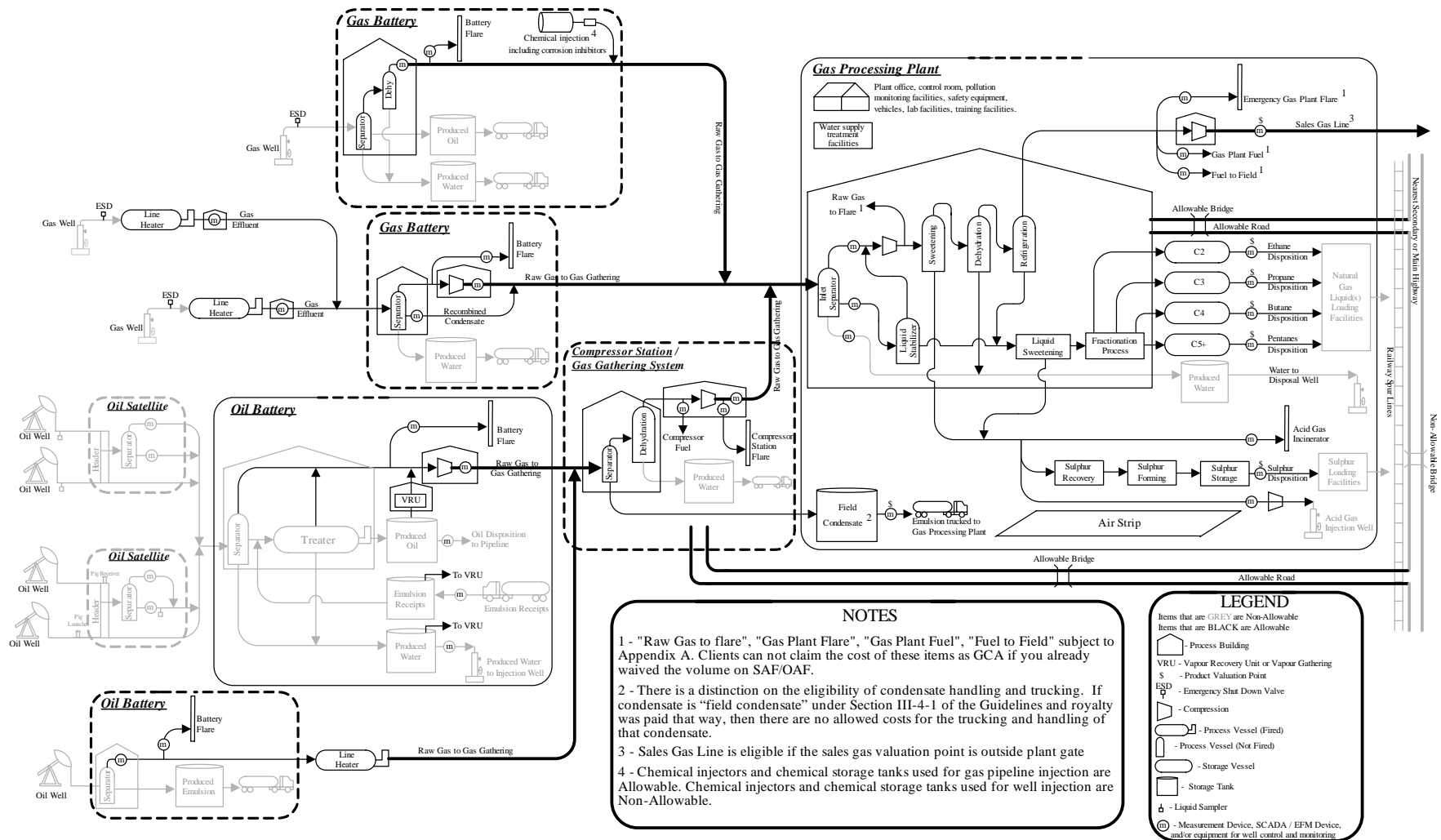

NOTES

1 - "Raw Gas to flare", "Gas Plant Flare", "Gas Plant Fuel", "Fuel to Field" subject to Appendix A. Clients can not claim the cost of these items as GCA if you already waived the volume on SAF/OAF.

2 - There is a distinction on the eligibility of condensate handling and trucking. If condensate is "field condensate" under Section III-4-1 of the Guidelines and royalty was paid that way, then there are no allowed costs for the trucking and handling of that condensate.

3 - Sales Gas Line is eligible if the sales gas valuation point is outside plant gate

4 - Chemical injectors and chemical storage tanks used for gas pipeline injection are Allowable. Chemical injectors and chemical storage tanks used for well injection are Non-Allowable.

LEGEND

Items that are GREY are Non-Allowable
 Items that are BLACK are Allowable

- Process Building
- Vapour Recovery Unit or Vapour Gathering
- Product Valuation Point
- Emergency Shut Down Valve
- Compression
- Process Vessel (Fired)
- Process Vessel (Not Fired)
- Storage Vessel
- Storage Tank
- Liquid Sampler
- Measurement Device, SCADA / EFM Device, and/or equipment for well control and monitoring