

Appendix B

Volumetric Reconciliation

1. Introduction

The department performs volumetric data reconciliation to ensure that mineral quantities that have potential impact on royalty calculations are accurately reported for each production period. The Ensure - Complete process determines all Crown disadvantage volumes to be provisionally assessed.

Three separate reconciliation processes are performed:

1. A reconciliation of all volumetric data that does not have appropriate allocations. The following situations are included in this category.
 - a. A SAF has not been filed when required.
 - b. An OAF has not been filed when required.
 - c. A SAF that has an error in one or more of the stream details so that the total factors do not equal 1.
 - d. An OAF that has an error in one or more of the owner details so that the total factors do not equal 1.
 - e. A missing SAF response to a cascade.
 - f. A missing OAF associated to a SAF response to a cascade.
 - g. The details for a SAF or OAF were deleted.
2. A reconciliation of all volumetric data at a meter station to determine negative metering differences.
 - Balancing of volumetric data at each meter station will identify any differences resulting from the “ins” minus the “outs” for gas and is referred to as a metering difference.
3. A reconciliation of CSO volume allocations.
 - Determine all meter stations with common stream operators, where allocations for royalty liable volumes have not been filed.

Examples are provided.

a. A SAF has not been filed when required.

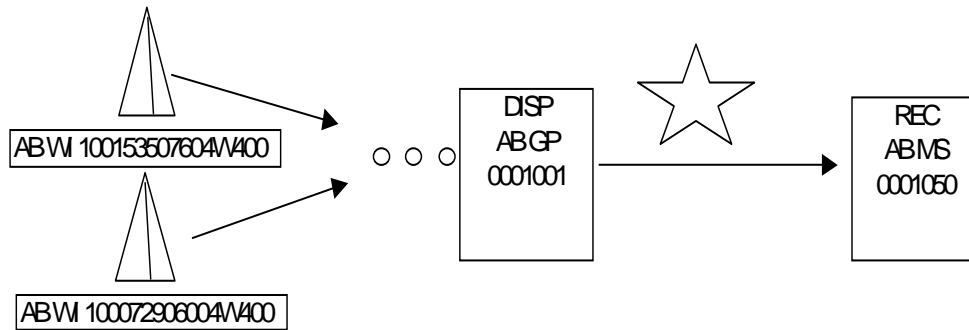

	*Reporting Facility	Activity	Product	*To/From Facility	Vd	ISC Breakdown	ISC Vd	Heat	Client Volumetric		
									Charge Facility	Vd	GJ
Volumetric	ABGP0001001	DISP	GAS	ABMS0001050	10500	C1-IC	8400	344400	PA	10500	430500
						C2-IC	525	21525			
						C5-IC	1575	64575			
						Total	10500	430500			
						Stream Id		SAF Factor			
SAF	ABGP0001001	DISP	GAS	ABMS0001050		ABVM 100153507604\400		0.55	Missing		
						ABVM 100072906004\400		0.45			
						Owner		OAF Factor			
OAF	ABGP0001001	DISP	GAS	ABMS0001050		ABVM 100153507604\400	XXX1	0.3	ABGP0001001	XXXX	XXXX
							XXX2	0.7	ABGP0001001	XXXX	XXXX
OAF	ABGP0001001	DISP	GAS	ABMS0001050		ABVM 100072906004\400	XXX3	1	ABGP0001001	XXXX	XXXX

b. An OAF has not been filed when required.

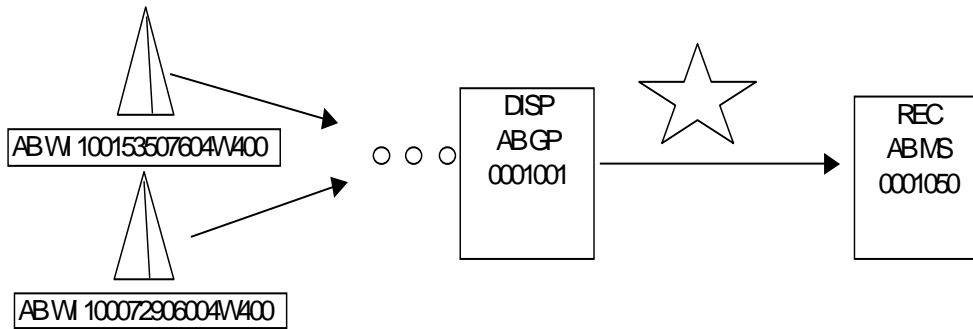

	*Reporting Facility	Activity	Product	*To/From Facility	Vol	ISCBreakdown	ISC Vol	Heat	Client Volumetric			
									Charge Facility	Vol	GJ	
Volumetric	AB GP 0001001	DISP	GAS	AB MS 0001050	10500	C1-IC	8400	344400	PA	10500	430500	
						C2-IC	525	21525				
						C5-IC	1575	64575				
						Total	10500	430500				
						StreamId		SAF Factor				
SAF	AB GP 0001001	DISP	GAS	AB MS 0001050		ABVM 100153507604/V400		0.55				
						ABVM 100072906004/V400		0.45				
						Owner		OAF Factor				
OAF	AB GP 0001001	DISP	GAS	AB MS 0001050		ABVM 100153507604/V400	XXX1	0.3	Missing	AB GP 0001001	XXXX	XXXX
							XXX2	0.7		AB GP 0001001	XXXX	XXXX
OAF	AB GP 0001001	DISP	GAS	AB MS 0001050		ABVM 100072906004/V400	XXX3	1		AB GP 0001001	XXXX	XXXX

c. A SAF that has an error in one or more of the stream details so that the factors do not add up to 1.00.

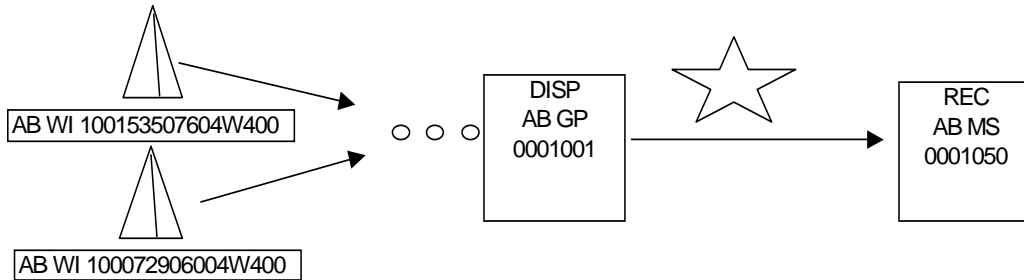

	*Reporting Facility	Activity	Product	*To/From Facility	Vol	ISC Breakdown	ISC Vol	Heat	Client Volumetric	
									Charge Facility	Vol
Volumetric	AB GP 0001001	DISP	GAS	AB MS 0001050	10500	C1-IC	8400	344400	PA	4725.0
						C2-IC	525	21525		
						C5-IC	1575	64575		
						Total	10500	430500		
						Stream Id		SAF Factor		
SAF	AB GP 0001001	DISP	GAS	AB MS 0001050		AB WI 100153507604W400		0.55		
						AB WI 1XX072906004W400		0.45	Invalid Stream	
						Owner	OAF Factor			
OAF	AB GP 0001001	DISP	GAS	AB MS 0001050		AB WI 100153507604W400	XXX1	0.3	AB GP 0001001	1732.5
							XXX2	0.7	AB GP 0001001	4042.5
OAF	AB GP 0001001	DISP	GAS	AB MS 0001050		AB WI 100072906004W400	XXX3	1	AB GP 0001001	XXXX
										5775.0

d. An OAF that has an error in one or more of the owner details so that the OAF factors for a stream do not add up to 1.

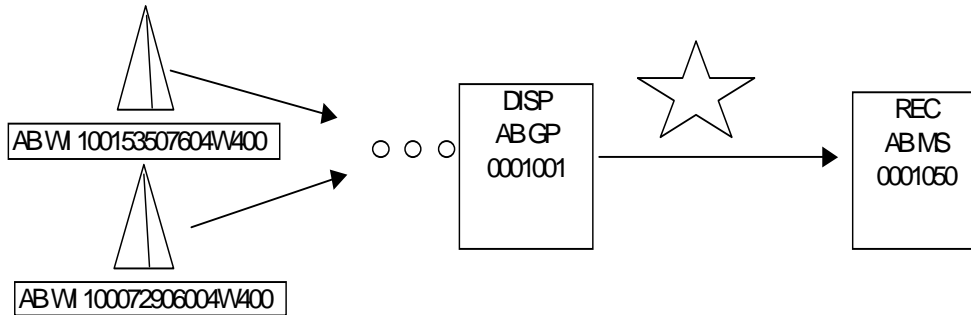

	Reporting Facility	Activity	Product	*To/From Facility	Vd	ISC Breakdown	ISC Vol	Heat	Client Volumetric		
									Charge Facility	Vd	GJ
Volumetric	AB GP 0001001	DISP	GAS	AB MS 0001050	10500	C1-IC	8400	344400	PA	4725.0	193725
						C2-IC	525	21525			
						C5-IC	1575	64575			
						Total	10500	430500			
						Stream Id		SAF Factor			
SAF	AB GP 0001001	DISP	GAS	AB MS 0001050		AB VM 100153507604\N400		0.55			
						AB VM 100072906004\N400		0.45			
						Owner	OAF Factor				
OAF	AB GP 0001001	DISP	GAS	AB MS 0001050		AB VM 100153507604\N400	XXX1	0.3	AB GP 0001001	1732.5	71033
							XXX2	0.7	AB GP 0001001	4042.5	165743
OAF	AB GP 0001001	DISP	GAS	AB MS 0001050		AB VM 100072906004\N400	XXX3	1	Invalid Owner AB GP 0001001	XXXX	XXXX
										5775.0	236776

e. A missing SAF response to a cascade.

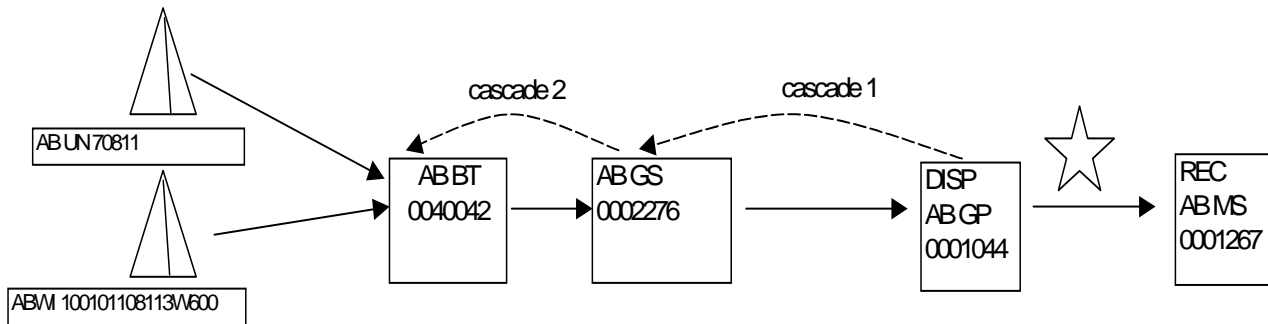

	Reporting Facility	Activity	Product	To/From Facility	Vol	ISC Breakdown	ISC Vol	Heat		Client Volumetric	
Volumetric	AB GP 0001044	DISP	GAS	AB MS 0001267	10475	C1-IC	4713.8	193263.75		Charge Facility	Vol
						C2-IC	5761.3	236211.25		PA	10475.0
						Total	10475	429475			
						Stream Id		SAF Factor	Cascade Fac		
SAF	AB GP 0001044	DISP	GAS	AB MS 0001267		AB GS 0002276		1			
SAF	AB GS 0002276	DISP	GAS	AB MS 0001267		AB BT 0040042		1	AB GP 0001044	Missing	
SAF	AB BT 0040042	DISP	GAS	AB MS 0001267		AB UN 70811		0.55	AB GS 0002276		
						AB VM 100113602607/V400		0.45			
							Owner	OAF Factor			
OAF	AB BT 0040042	DISP	GAS	AB MS 0001267		AB UN 70811	XXX1	0.3	AB GS 0002276	AB GP 0001044	XXXX
							XXX2	0.7	AB GS 0002276	AB GP 0001044	XXXX
OAF	AB BT 0040042	DISP	GAS	AB MS 0001267		AB VM 100113602607/V400	XXX3	1	AB GS 0002276	AB GP 0001044	XXXX

f. A SAF response to a cascade is missing the associated OAF.

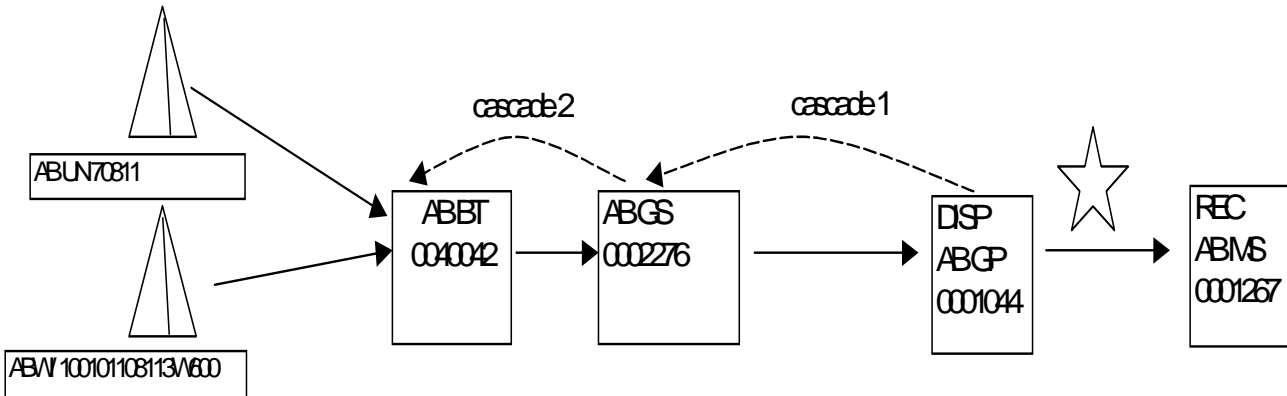

	Reporting Facility	Activity	Prod Lst	To/From Facility	Vd	ISCBreakdown	ISCVol	Heat		Client Volumetric		
Volumetric	ABGP0001044	DISP	GAS	ABMS0001267	10475	CHC	47138	193263.75		Charge Facility	Vd	
						C2HC	5761.3	236211.25		PA	47138	
						Total	10475	429475				
						StreamId		SAF Factor	Cascade Fac			
SAF	ABGP0001044	DISP	GAS	ABMS0001267		ABGS0002276		1				
SAF	ABGS0002276	DISP	GAS	ABMS0001267		ABBT0040042		1	ABGP0001044			
SAF	ABBT0040042	DISP	GAS	ABMS0001267		ABUN70811		0.55	ABGS0002276			
						ABW 100113602607/1400		0.45				
							Owner	OAF Factor				
OAF	ABBT0040042	DISP	GAS	ABMS0001267		ABUN70811	XXX1	0.3	ABGS0002276	ABGP0001044	1728.4	
							XXX2	0.7	ABGS0002276	ABGP0001044	4032.9	
OAF	ABBT0040042	DISP	GAS	ABMS0001267		ABW 100113602607/1400	XXX3	1	ABGS0002276	Missing	ABGP0001044	XXXX
											5761.3	

g. The details for a SAF or OAF were deleted.

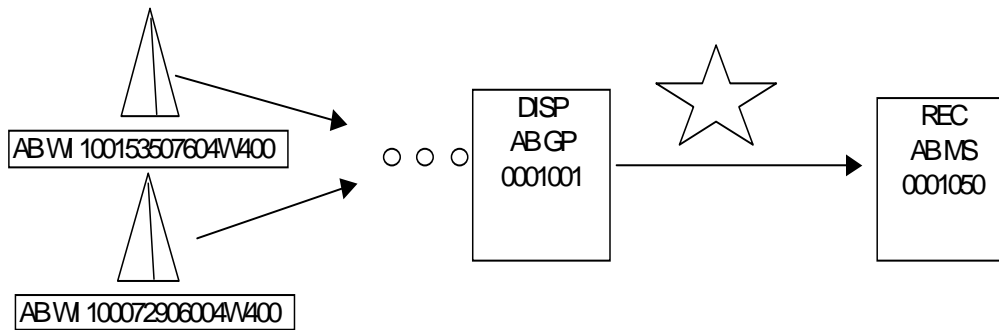

	*Reporting Facility	Activity	Product	*To/From Facility	Vol	ISC Breakdown	ISC Vol	Heat	Client Volumetric		
									Charge Facility	Vol	GJ
Volumetric	AB GP 0001001	DISP	GAS	AB MS 0001050	10500	C1-IC	8400	344400	PA	10500	430500
						C2-IC	525	21525			
						C5-IC	1575	64575			
						Total	10500	430500			
						Stream Id		SAF Factor			
SAF	AB GP 0001001	DISP	GAS	AB MS 0001050		AB VM 100153507604\W400		0.55	Deleted		
						AB VM 100072906004\W400		0.45			
							Owner	OAF Factor			
OAF	AB GP 0001001	DISP	GAS	AB MS 0001050		AB VM 100153507604\W400	XXX1	0.3	AB GP 0001001	XXXX	XXXX
							XXX2	0.7	AB GP 0001001	XXXX	XXXX
OAF	AB GP 0001001	DISP	GAS	AB MS 0001050		AB VM 100072906004\W400	XXX3	1	AB GP 0001001	XXXX	XXXX

2. Select all negative metering differences

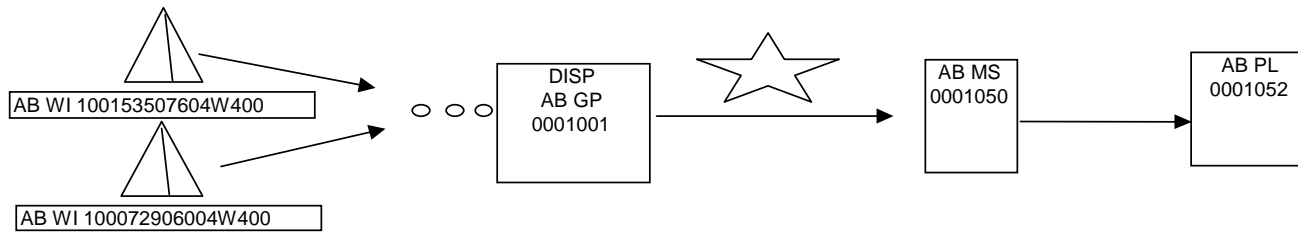

	*Reporting Facility	Activity	Product	*To/From Facility	Vol	ISC Breakdown	ISC Vol	Heat	Client Volumetric	Charge Facility	Vol
Volumetric	AB PL 0001052	REC	GAS	AB MS 0001050	105,000	C1-IC	84000	3444000	} Filed by Op PL		
						C2-IC	5250	215250			
						C5-IC	15750	645750			
							105000	4305000			
	AB MS 0001050	DISP	GAS	AB PL 0001052	105,000	C1-IC	84000	3444000	} Autogenerated	AB MS 0001050	-500.0
Reconciliation Must be setup as CSO to be Prov Ass						C2-IC	5250	215250			
						C5-IC	15750	645750			
							105000	4305000		PA - Negative Metering Di	
	AB MS 0001050	Rec	GAS	AB GP 0001001	104,500	C1-IC	83600	3427600	} Filed by Op MS		
						C2-IC	5225	214225			
						C5-IC	15675	642675			
							104500	4284500			
Volumetric	AB GP 0001001	DISP	GAS	AB MS 0001050	104,500	C1-IC	83600	3427600	} Autogenerated		
						C2-IC	5225	214225			
						C5-IC	15675	642675			
						Total	104500	4284500			
SAF	AB GP 0001001	DISP	GAS	AB MS 0001050		Stream Id		SAF Factor			
						AB WI 100153507604W400		0.55			
						AB WI 100072906004W400		0.45			
OAF	AB GP 0001001	DISP	GAS	AB MS 0001050		Owner		OAF Factor			
						AB WI 100153507604W400	XXX1	0.3	Crown Royalty	AB GP 0001001	17242.5
							XXX2	0.7	Crown Royalty	AB GP 0001001	40332.5
OAF	AB GP 0001001	DISP	GAS	AB MS 0001050		AB WI 100072906004W400	XXX3	1	Crown Royalty	AB GP 0001001	47025.0
											104500.0

3. Unallocated CSO volumes.

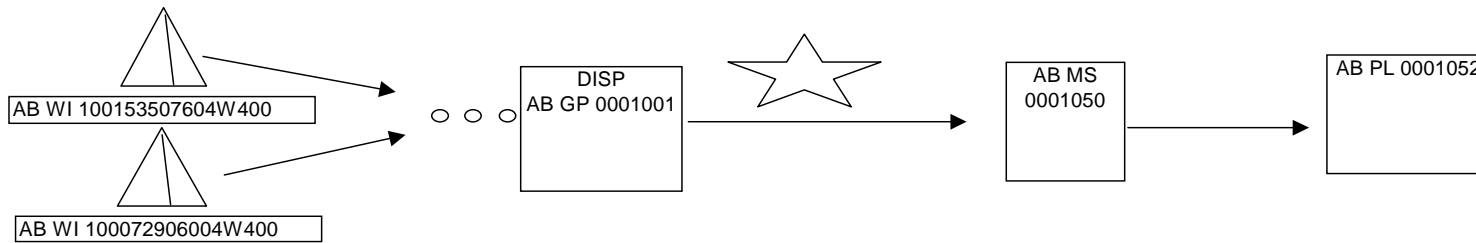

	*Reporting Facility	Activity	Product	*To/From Facility	Vol	ISC Breakdown	ISC Vol	Heat	Client Volumetric
Volumetric	AB PL 0001052	REC	GAS	AB MS 0001050	105,000	C1-IC	84000	3444000	Filed by Op PL
						C2-IC	5250	215250	
						C5-IC	15750	645750	
							105000	4305000	
	AB MS 0001050	DISP	GAS	AB PL 0001052	105,000	C1-IC	84000	3444000	Autocreated
						C2-IC	5250	215250	
						C5-IC	15750	645750	
							105000	4305000	
	AB MS 0001050	Rec	GAS	AB GP 0001001	104,500	C1-IC	83600	3427600	Missing
						C2-IC	5225	214225	
						C5-IC	15675	642675	S/B filed by Op MS
							104500	4284500	
Volumetric	AB GP 0001001	DISP	GAS	AB MS 0001050	104,500	C1-IC	83600	3427600	Missing
						C2-IC	5225	214225	
						C5-IC	15675	642675	
						Total	104500	4284500	
SAF	AB GP 0001001	DISP	GAS	AB MS 0001050		Stream Id		SAF Factor	Missing
						AB WI 100153507604W400		0.55	
						AB WI 100072906004W400		0.45	
OAF	AB GP 0001001	DISP	GAS	AB MS 0001050		Owner	XXX1	OAF Factor	Missing CR
						AB WI 100153507604W400		0.3	
							XXX2	0.7	
OAF	AB GP 0001001	DISP	GAS	AB MS 0001050		AB WI 100072906004W400	XXX3	1	Missing CR

2. Definitions

- Reporting Facility** - The reporting facility on the Volumetric/SAF/OAF refers to the number or code of a facility where an activity occurred. When reconciling volumes from the Volumetric/SAF/OAF, the reconciliation is tied to the facility referred to in the reporting facility location. (Refer to Registry training)
- From/to facility** - The facility that is sending or receiving volumetrics to the reporting facility. (refer to Registry training)
- Activity** - The description of the action occurring at the reporting facility. Examples of activities are disposition (DISP), metering difference (DIFF), receipt (REC), fuel (FUEL), and process (PROC)
- Net Quantities** - This is the owner's share of a volume or mass reported at a stream ID. Reconciliation uses net quantities reported by the combination of the Volumetric/SAF/OAF for each product/owner.
- Royalty Network** - The royalty network (as described *Appendix A, Royalty Triggers*) is a collection of interconnected processing and gathering facilities that receive products either directly or indirectly from reservoirs. The department deems the network to end when the product is delivered to:
- Commercial transportation facilities such as meter stations, pipelines, railcars, and trucks (except in the case where a processed gas stream is transferred to a pipeline for the purpose of being eventually used as eligible fuel);
 - Field straddle plants (except the case of unprocessed product where the network is deemed to end at the field straddle plant outlet gate whether or not any processing of the product occurs);
 - Mainline straddle plants;
 - Fractionation plants;
 - Facilities for the purpose of injection;
 - Facilities outside Alberta; and
 - Refineries, terminals, treating plants.

The term *royalty network*, as defined above, is intended to be used within the context of royalty assessment and volumetric reconciliation by the department.

3. Volumetrics with Missing Allocations (Reconciliation)

The volumetric allocation reconciliation is performed for all royalty liable gas at batteries, gathering systems, gas processing plants, field straddle plants, meter stations, and injection facilities. There is no volumetric reconciliation of mainline straddle plants, fractionation plants.

The EUB volumetric data, at a facility level, is compared to the SAF and OAF allocations reported by the facility operator for that facility. For each reconciliation product at the facility, the sum of the volumes allocated to each owner will be compared to the reported volumetrics from the reporting pipelines. If the sum of the reporting facility reported production is less than the volumetrics allocated from the pipeline, the operator of the facility provisionally assessed for the difference.

In the case of injection volumes potentially qualifying for royalty (injection) credit, the sum of reported injection receipts will be compared to the dispositions to the injection facility reported. If the sum of the reported injection receipts is greater than the disposition volume, the operator of the injection facility will be provisionally assessed for the difference.

3.1 Metering Differences Reconciliation

For each reconciliation product, the sum of the volume received in, at the meter station, is compared to the disposition out from the meter station. The common stream operator of the meter station is provisionally assessed for the difference.

3.2 Unallocated CSO Reconciliation

Gas volumes received at a meter station; from common streams require allocation reporting (refer to Registry reporting). The department reconciles pipeline receipts from a meter station to allocations reported by the common stream operator. The common stream operator is provisionally assessed for the unallocated volumes.

4. Ensure Complete Reports

The department performs the Stream Allocation Factor (SAF) and Owner Allocation Factor (OAF) Ensure Complete process two days prior to the DOE deadline for allocation submissions, and provides the results on the DOE Ensure Complete Process Results report. The DOE version is slightly different from the one created by the Registry SAF/OAF Ensure Complete process. The DOE version only reports errors that would result in provisional assessment charges, whereas the Registry version reports all error situations where SAF's and OAF's are expected to be filed. In addition, the report includes errors that would be levied against Common Stream Operators (CSO) at the meter station level. If the DOE Ensure Complete report displays the message "REQUIRED ALLOCATIONS COMPLETE" no further reporting information is required and the facility is currently balanced with all volumes accounted for at that facility. The DOE SAF/OAF Ensure Complete Process Results report is sent to facility and common stream operators and will provide the following reporting errors so operators can respond to them before provisional assessment charges are levied:

DOE Ensure Complete Error	Error Explanation
Missing SAF	No SAF filed for DOE required volumetric activity
Missing SAF (Cascaded)	No SAF filed for cascaded allocation of a DOE required volumetric activity
Missing OAF	No OAF filed for DOE required volumetric activity
Invalid Owner Id	Invalid Owner on OAF for DOE required volumetric activity
Invalid Stream Id	Invalid Stream on SAF/OAF for DOE required volumetric activity
No SAF detail row	SAF details are not available for DOE required volumetric activity
No OAF detail row	OAF details are not available for DOE required volumetric activity
No SAF detail row for a cascade	SAF details for a cascaded allocation are not available for DOE required volumetric activity
Metering Difference	Volumetric difference reported by common stream operator at meter station
Unallocated CSO Volume	Unallocated volumes by common stream operator at meter station

5. Volumetric Reconciliation Discrepancy Letters

To assist facility operators in resolving volumetric reconciliation discrepancies, the department includes the following reports with the monthly invoice package sent to facility operators:

Provisional Assessment Summary

- Displays all PA transactions for the particular invoice noted on the header information of the report.
- The royalty client total on this report will appear in the charges category on the invoice as either a charge or a reversal.
- Access on the Registry through the *Ministry Invoices and Statements* menu option, then the *Manage Invoices and Statements* menu option.
- The report package is *Client Package – Monthly Reports*.
- This report is sent to the client with each invoice run.

Outstanding Provisional Assessment Discrepancies

- Displays all outstanding PA discrepancies for the client:
 - Pre and post Registry
 - Open and closed years (non statute barred)
 - Crown disadvantage only (PA charged)
- Access on the Registry through the *Ministry Invoices and Statements* menu option, then the *Manage Invoices and Statements* menu option.
- The report package is *Client Package – Monthly Reports*.
- This report is sent to the client with each invoice run.

6. Provisional Assessment for Volumetric Reconciliation Discrepancies

A provisional assessment will be levied on the facility operator for each volumetric reconciliation discrepancy that is greater than the designated volume tolerance at the time of invoicing. The provisional assessment is calculated as follows:

Volume Discrepancy ...multiplied by... 35% ...multiplied by... Product Reference Price for the production month

7. Reconciliation Products

Volumetric reconciliation at a facility location will be performed for each reconciliation product group as listed below. Products in the group are rolled up to the resulting product code.

Product Grouping	Products in the Group	Resulting Product Code
Butane-MX	IC4-MX, NC4-MX, C4-MX	C4-MX
Butane-SP	IC4-SP, NC4-SP, C4-SP	C4-SP
Ethane-MX	C2-MX	C2-MX
Ethane-SP	C2-SP	C2-SP
Lite-MX	LITEMX, C1-MX, CO2-MX	LITEMX
Pentane-MX	IC5-MX, NC5-MX, C5-MX, C6-MX	C5-MX
Pentane-SP	IC5-SP, NC5-SP, C5-SP, C6-SP (exception to include OIL and COND if facility type is GP, GS)	C5-SP
Propane-MX	C3-MX	C3-MX
Sulphur	SUL, SPRILL, SMOLT, SBASE, SBLOC, SFORM, SLATE	SUL
Gas	Gas	Gas